

SKS200 AUTOMATIC AIR VENT



FIELDS

Automatic Airvent series SKS200 are suitable to eliminate automatically air in heating systems the following characteristics:

Max working pressure:	10 bar
Max discharge pressure:	2.5 bar
Max temperature of use:	110° C
Threading of connection:	ISO 228/1

LIST OF MATERIALS:

Metal of the body:	Brass Alloy CW617N - UNI EN 12165
Metal of the cap:	Brass Alloy CW617N - UNI EN 12165
Spring:	Stainless Steel
Float:	PP
Seals:	EPDM

AVAILABLE SIZES: 3/8" - 1/2", 3/4", 1"



Email: info@pipelineproductsindia.com
 Website: www.pipelineproductsindia.com

PIPELINE PRODUCTS (INDIA)

3374, HAUZ QAZI, DELHI-110006. INDIA.

PH:- 011 - 43211999, 011 -23240139 – 40,
 011 - 23264749, 011 - 23255853 – 54,
 011 - 23273058, 011 - 23281410

FAX : 011 - 43211901

MAIN SIZES OF SKS 200 AUTOMATIC AIRVENT:

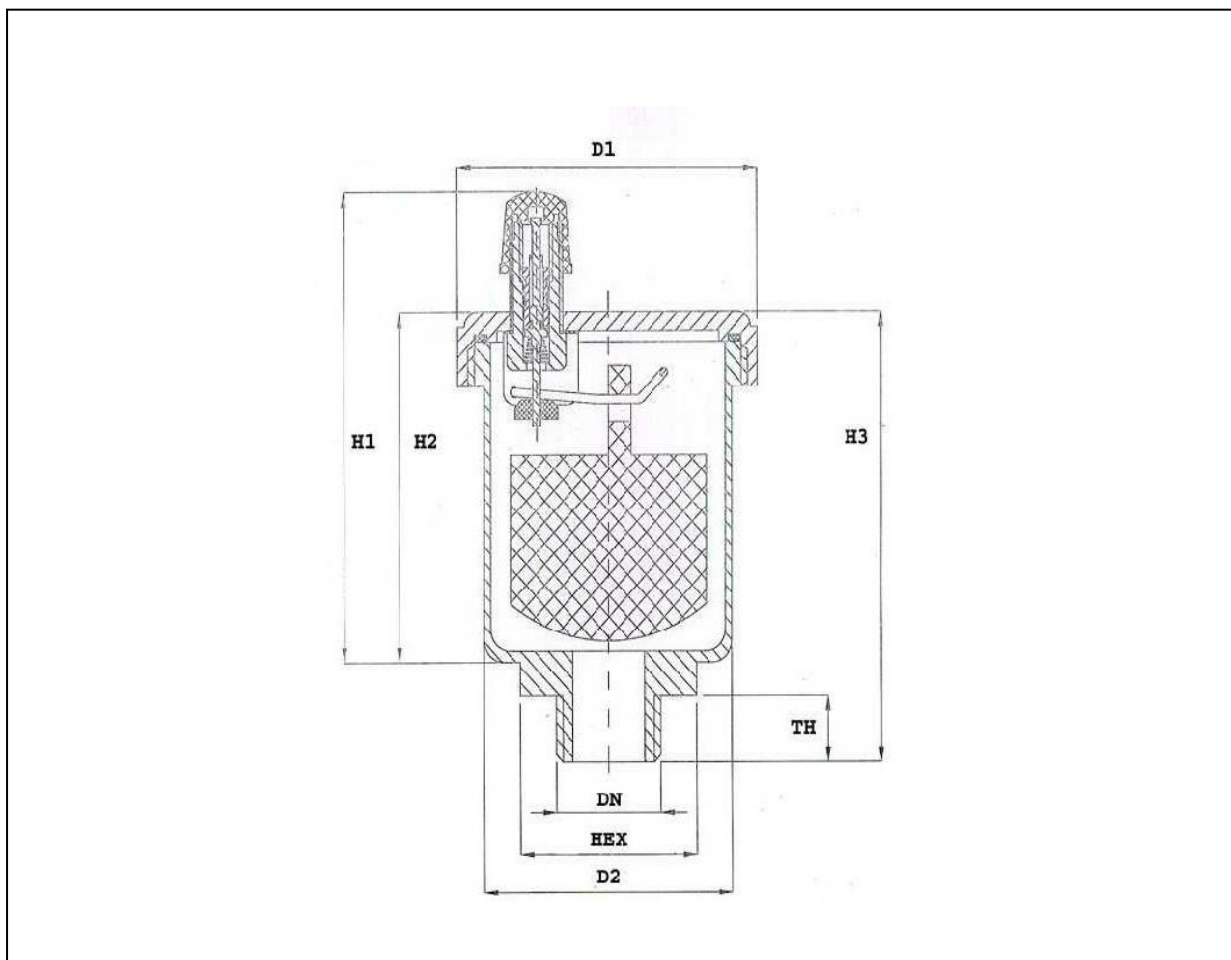

SKS 200 AUTOMATIC AIRVENT:

ITEM	DN	HEX	D1	D2	H1	H2	H3	TH
SKS200	3/8"	23	45.90	30	62.5	44.7	60.58	6.5
SKS200	1/2"	27	46	38	62.5	44.7	60.58	7.99
SKS200	3/4"	30	50.40	41.30	85.5	70.9	85	10.10
SKS200	1"	34	50.60	41.39	87.10	72.30	87	10.10

Dimension in mm.