

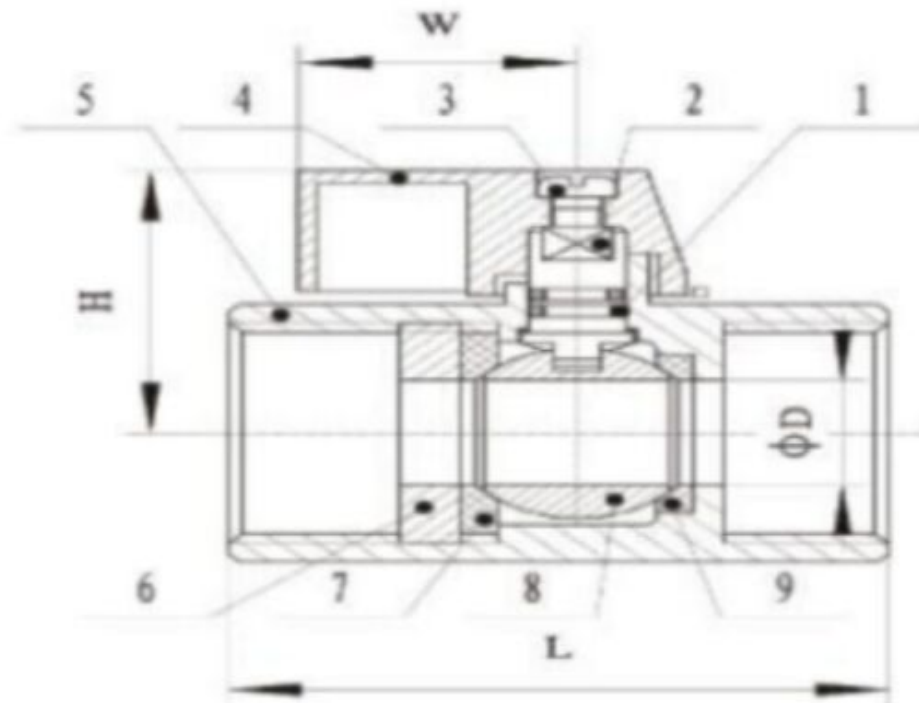

GA Drawing of SKS 211

FEATURES:

- 1000PSI/PN63
- Reduce Port
- Investment Casting
- Blow-Out Proof System.
- Sanitary Design
- Ped97/23/EC Approved
- Casting Approved AD2000-WO
- Thread: ASME B1.20.1 BS21.DIN2999, 259, ISO228-1, JIS B0203, ISO7/1
- Inspection Testing API598, EN12266



S. No	Name	Material
1.	O-RING	NBR
2.	STEM	S.S. 304 (CF8)
3.	BOLT	S.S. 304 (CF8)
4.	LEVER	ALUMINIUM ALLOY
5.	BODY	S.S. 304 (CF8)
6.	Cap	S.S. 304 (CF8)
7.	BALL SEAT (A)	PTFE
8.	BALL	S.S. 304 (CF8)
9.	BALL SEAT (B)	PTFE

Item/size	1/4"	3/8"	1/2"	3/4"	1"
D	7	7	9.2	12.5	15
H	26.5	26.5	28.3	31.5	34
W	22.8	22.8	22.8	22.8	22.8
L	42	42	46	54	65

TITLE: GA DRAWING	PROJECTION FIRST ANGLE	DESIGN SIGN S/A/B	SCALE 1.5:1
	ART. SKS 211	PIPELINE PRODUCTS <small>INDIA</small> Email: info@pipelineproducts.com Website: www.pipelineproducts.com	