

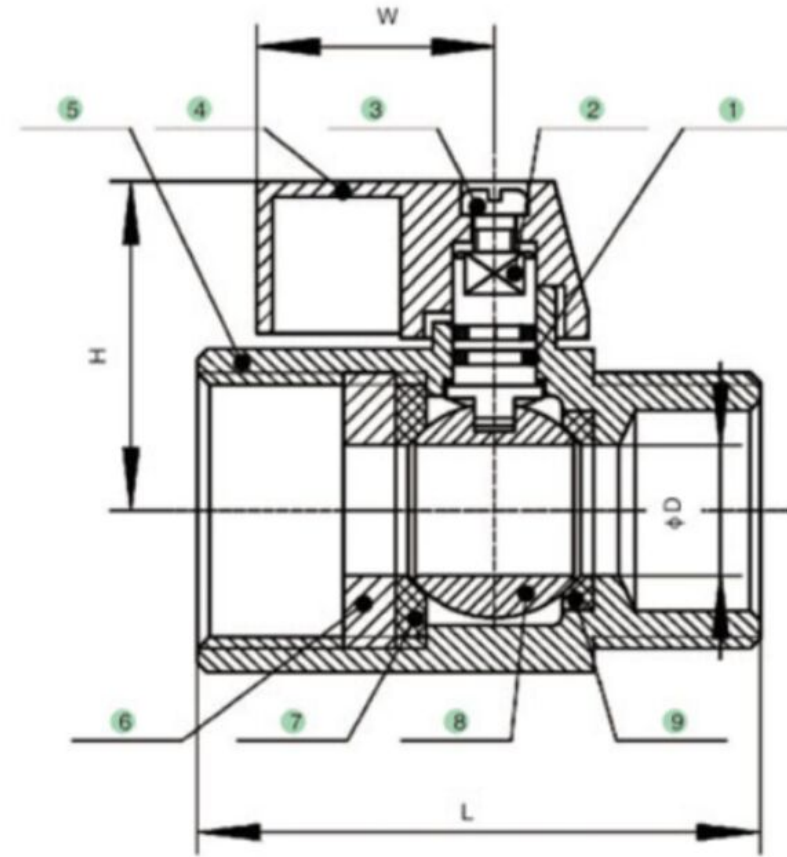

# GA Drawing of SKS 211MF

## FEATURES:

- 1000PSI/PN63
- Reduce Port
- Investment Casting
- Blow-Out Proof System.
- Sanitary Design
- Ped97/23/EC Approved
- Casting Approved AD2000-WO
- Thread: ASME B1.20.1 BS21.DIN2999, 259, ISO228-1, JIS B0203, ISO7/1
- Inspection Testing API598, EN12266



S. No	Name	Material
1.	BODY	S.S. 304 (CF8)
2.	BALL	S.S. 304 (CF8)
3.	SEAT	PTFE
4.	HANDLE	ALUMINIUM ALLOY
5.	STEM	S.S. 304

Item/size	1/4"	3/8"	1/2"	3/4"	1"
D	7	7	9.2	12.5	15
H	26.5	26.5	28.3	31.5	34
W	22.8	22.8	22.8	22.8	22.8
L	42	42	46	54	65

TITLE: <b>GA DRAWING</b>	PROJECTION MEANS	PRIMO ANGLE OF VIEW	DRAWING UNIT
	DESIGN SIGN <b>SAB</b>	G.W. N.W. 102.4g	SCALE 1.5:1
PAGE 1 OF 1			
ART. <b>SKS 211MF</b>	 <small>Email: info@pipelineproductsindia.com Website: www.pipelineproductsindia.com</small>		