

PT No.	PART NAME	MATERIAL
1	BODY	CI
2	SEAT	EPDM
3	PLATES	D.I. (LAPPED) ENP
4	SHAFT	SS304
5	SPRING	SS304
6	O-RING	NITRILE / EPDM
7	PLUG	M.S. (CROME PLATED)
8	WASHER	STAINLESS STEEL

SIZE	RATING	40	50	65	80	100	125	150	200	250	300	350	400	450	500
ØA	PN16	52	63	75	92	116	145	169	220	273	324	357	407	457	508
ØB	PN16	80	100	120	130	170	192	215	275	335	405	447	510	545	602
H	PN16	43	54	54	57	64	70	76	95	108	143	184	191	203	213

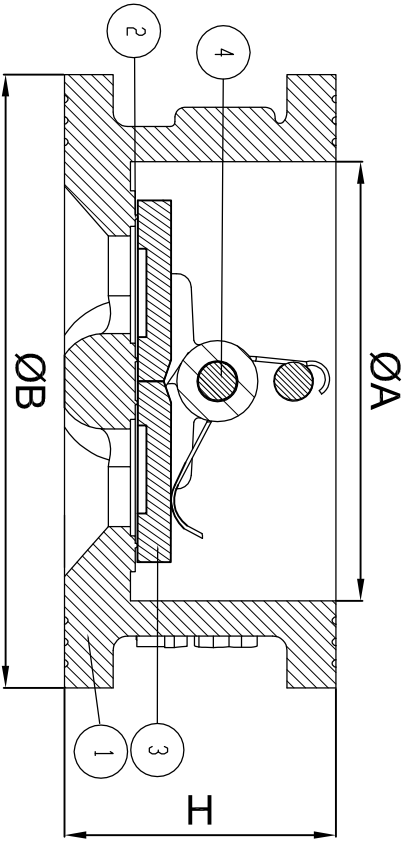

HYDROSTATIC TEST PRESSURE	
BODY (kg/cm <sup>2</sup> )	SEAT (kg/cm <sup>2</sup> )
24	17.6

**PIPELINE PRODUCTS INDIA**

3374, Hauz Qazi  
Near Chawri Bazaar Metro Station

TITLE : GENERAL ASSEMBLY DRAWING  
CLIENT : PIPELINE PRODUCTS INDIA  
GAD NO : 19DPDT0001-02  
VALVE TYPE : DUAL PLATE CHECK VALVE  
MODEL : SKS310D  
SEAT : SOFT SEATED

**SECTION A-A**

ALL DIMENSIONS ARE IN MM UNLESS OTHERWISE STATED. UNSPECIFIED TOLERANCES ACCORDING TO IS:2102(MEDIUM)

REV.	DATE	DESCRIPTION	DRN. BY	CHD. BY	APP. BY
A	21/06/2019	ISSUE FOR APPROVAL	VJ	SD	RKV

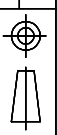

SCALE  
N.T.S

SHEET 1 OF 1