

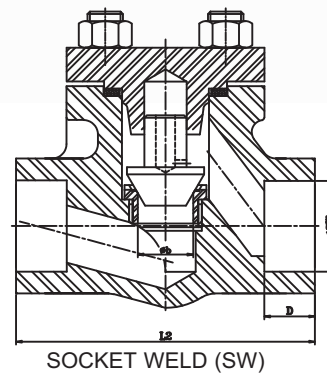

FORGED STEEL CHECK VALVES - BSEN ISO 15761, API 602, ASME B16.34

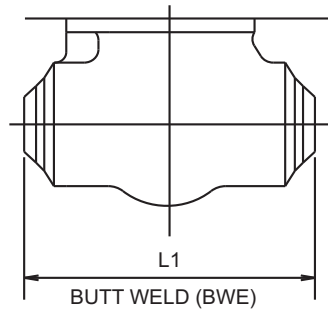
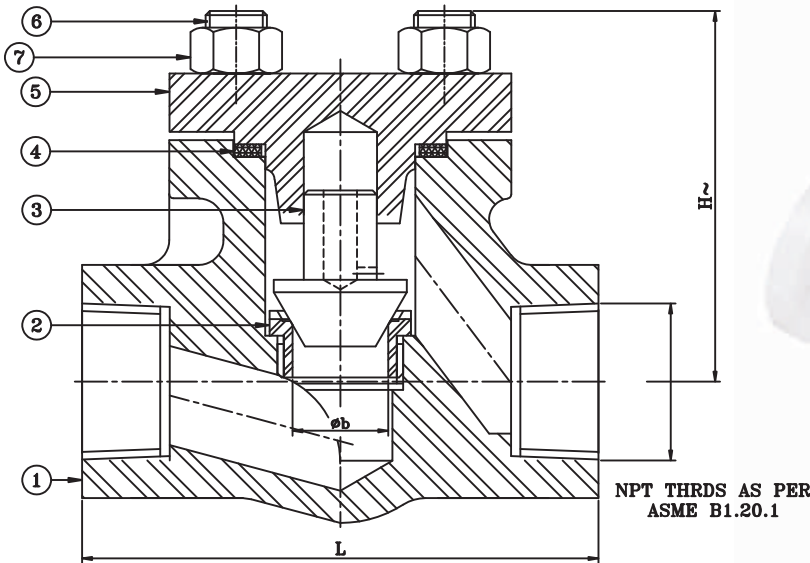

STANDARD MATERIAL COMBINATION

P.No.	Description	Carbon Steel to ASTM			Alloy Steel to ASTM				Stainless Steel to ASTM			
		A105	A350LF2	A182F5	A182F11	A182F22	A182F9	A182F304	A182F316	A182F304L	A182F316L	
1	BODY	A105	A350LF2	A182F5	A182F11	A182F22	A182F9	A182F304	A182F316	A182F304L	A182F316L	
2	SEAT RING	As per Trim Material Combination										
3	WEDGE	As per Trim Material Combination										
4	GASKET	Stainless steel + Graphoil										
5	COVER	A105	A350 LF2	A182F5	A182F11	A182F22	A182F9	A182F304	A182F316	A182F304L	A182F316L	
6	STUDS	A193 B7	A320 L7	A193 B7	A193 B16	A193B16	A193B16	A193 B8	A193 B8	A193 B8	A193 B8	
7	NUTS	A194 2H	A194 Gr.4	A194 2H	A194 Gr.4	A194 Gr.4	A194 Gr.8	A194 Gr.8	A194 Gr.8	A194 Gr.8	A194 Gr.8	

Body Material Combination with ASTM A F304H, F316H, F321, F347 also provided.

Valves can be supplied in other MOC's on request:-
SS (ASTM A 182 Gr.F304H/ F321) , DSS (ASTM A 182 Gr.F50 /F51/ F53/F55)



FORGED STEEL CHECK VALVES - BSEN ISO 15761, API 602, ASME B16.34

TRIM MATERIAL COMBINATION (ON REQUEST)

Trim No.	Seat Ring Face	Wedge Seat Face	Stem	Backseat Bush	Lantern Ring
1	F6a/13%Cr.	F6a/13%Cr.	F6a/AISI410	F6a/AISI410	F6a/AISI410
2	F304	F304	F304/AISI304	F304/AISI304	F304/AISI304
5	STELLITE	STELLITE	F6a/AISI410	F6a/AISI410	F6a/AISI410
8	STELLITE	F6a/13%Cr.	F6a/AISI410	F6a/AISI410	F6a/AISI410
9	MONEL	MONEL	MONEL	MONEL	MONEL
10	F316	F316	F316/AISI1316	F316/AISI1316	F316/AISI1316
12	316+STELLITE	316	F316/AISI316	F316/AISI316	F316/AISI316
13	ALLOY 20	ALLOY 20	ALLOY 20	ALLOY 20	ALLOY 20

NOTE: Other Trim Combination can be provided as Trim Material Combination.

*All dimensions in mm

DIMENSIONAL DATA CLASS -800 (REDUCED BORE)

DN	NPS	b	L1(BWE)	L2(SWE)	H	SWE		D	Aprox. Wt.⚡
						BS 3799	ASME B16.11		
15	½	10	80	80	55	+0.3 21.8 -0.0	22.2 21.8	11	1.15
20	¾	12.7	88	88	60	+0.3 27.4 -0.0	27.6 27.2	14	1.450
25	1	18	100	100	78	+0.3 34.1 -0.0	34.3 33.9	14	2.2
40	1 ½	30	145	145	97	+0.3 49 -0.0	49.2 48.8	14	5.4
50	2	35	170	170	120	+0.3 61 -0.0	61.7 61.2	17	7

NOTE: The above data is subject to change without notice due to our continuing product improvement program. (⚡WEIGHT GIVEN IN KGS)

TEST PRESSURES

CLASS	SHELL TEST (HYDROSTATIC)		SEAT TEST			
			HYDROSTATIC		PNEUMATIC	
800	207 Bar	3003 Psi g	152 Bar	2205 Psi g	N.A.	N.A.