

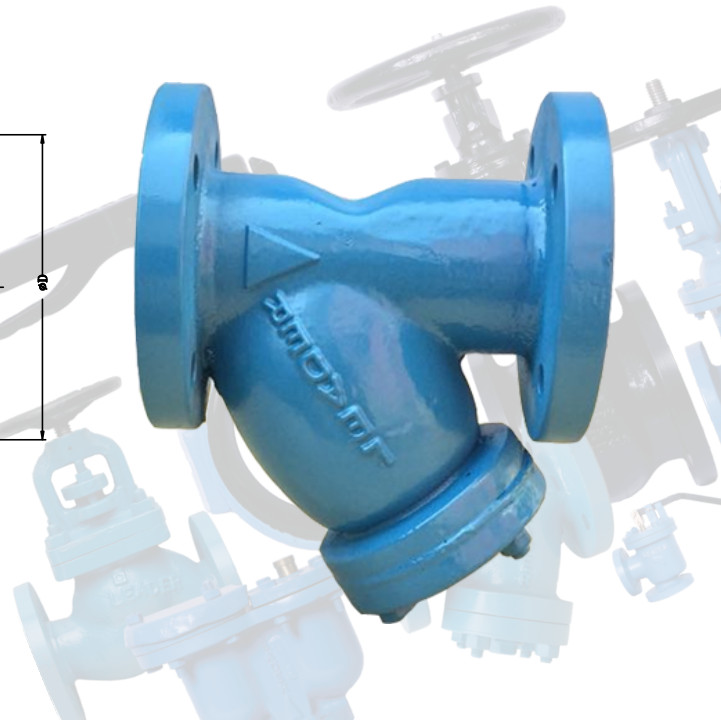

CAST IRON 'Y' TYPE STRAINER FLANGE ENDS

SPECIFICATIONS:

SS (TYPE 304) SCREEN HAVING
1MM DIA PERFORATIONS,
FLANGES AS PER BS: 10
TABLE 'E' (FF)

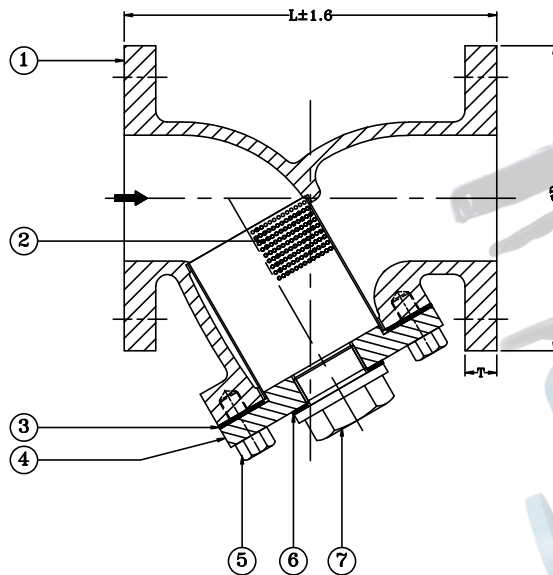

ITEM	SIZES	ITEM CODE	END DETAILS
CAST IRON 'Y' TYPE STRAINER FLANGED ENDS	40mm TO 300mm	CI-0093	FLANGED ENDS AS PER BS 10 TABLE 'E' (FF)

STANDARD MATERIAL COMBINATION

SR. NO.	NAME OF PARTS	NO. OFF	MATERIAL	SPECIFICATION/STANDARD
1.	BODY	1	C.I.	BSEN 1561 Gr. GJL200
2.	SCREEN	1	S.S.	TYPE 304
3.	GASKET	1	C.N.A.F.	IS 2712 Gr. C
4.	COVER	1	C.I.	BSEN 1561 Gr. GJL200
5.	BOLTS	TO SUIT	CARBON STEEL	BS 4190
6.	GASKET	1	C.N.A.F.	--
7.	DRAIN PLUG	1	C.I.	BSEN 1561 Gr. GJL200

DIMENSION DATA

NOMINAL SIZE	40MM	50MM	65MM	80MM	100MM	125MM	150MM	200MM	250MM	300MM
FACE TO FACE (L)	190	190	200	263	294	360	378	430	510	593
FLANGE THICKNESS (T)	15.8	19.1	19.1	19.1	22.2	22.2	22.2	25.4	25.4	28.6
FLANGE DIAMETER (ØD)	133.5	152.4	165.1	184.1	216	254	279.4	336.5	406.4	457.2

ITEM	SIZES	TEST PRESSURES	TESTING STANDARD
		BODY	
CAST IRON 'Y' TYPE STRAINER FLANGED ENDS	40mm to 300mm	18 kg/cm ² (Hyd.)	Manufacturer

NOTE: 1.The above data is subject to change without notice due to our continual product improvement program.
2.Valves Can be supplied in other MOC's on request, Cast Iron (IS 210 Gr. FG 260) Ductile Iron (ASTMA 395 Gr. 60-40-18 / 65-45-15 / GGG 40.30) & D2 (ASTMA 439 Gr. D2/ D2A/ D2B/ D2C)