

SIZE	40	50	65	80	100	125	150	200	250	300	350	400	450	500
ØB	52.00	63.00	75.00	92.00	116.00	145.00	169.00	220.00	273.00	324.00	357.00	407.00	457.00	508.00
ØA	80.00	100.00	120.00	130.00	170.00	192.00	215.00	275.00	335.00	405.00	447.00	510.00	545.00	602.00
H	43.00	54.00	54.00	57.00	64.00	70.00	76.00	95.00	108.00	143.00	184.00	191.00	203.00	213.00

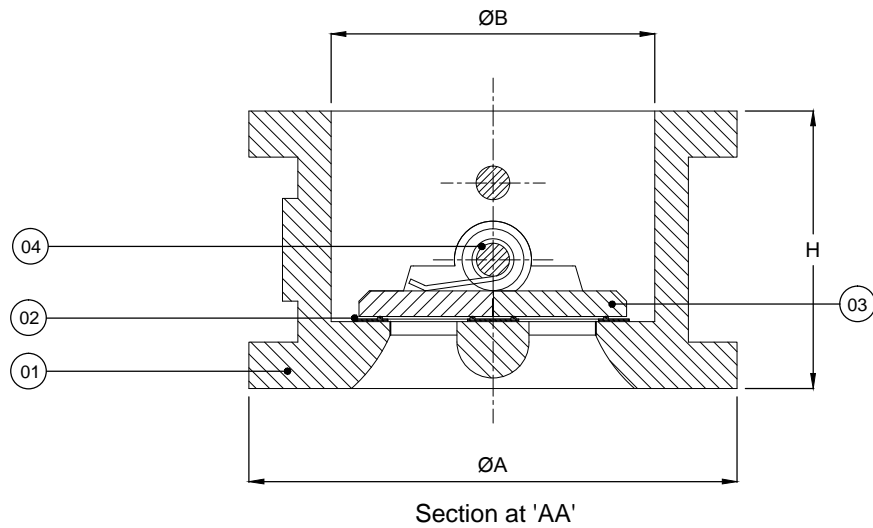
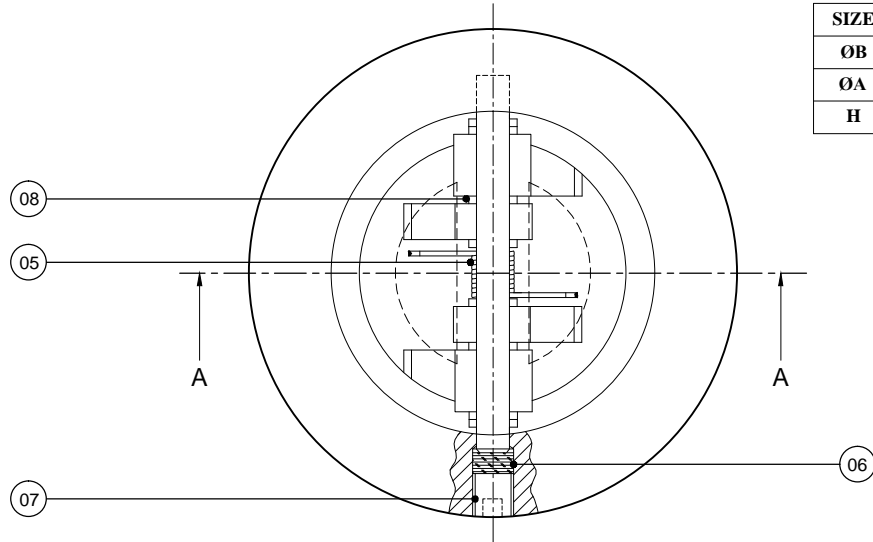

PT No.	PART NAME	MATERIAL
01	BODY	D.I
02	SEAT	EPDM
03	PLATES	D.I. (LAPPED) ENP
04	SHAFT	SS304
05	SPRING	SS304
06	O RING	NITRILE
07	PLUG	M. S. (CHROME PLATED)
08	WASHER	STAINLESS STEEL

Model No. - SKS320D

PIPELINE PRODUCTS (INDIA)	Date	Name	Material : ****	Scale : N.T.S
	Dm. 8/02/2016	Er. Rahul		
	Chd. 8/02/2016	Des Raj	QTY : ****	
This drawing is exclusive property of PIPELINE PRODUCTS (INDIA). It should not be reproduced in whole or in part without the written consent of PIPELINE PRODUCTS (INDIA).	Std. 8/02/2016		Raw Size : ****	M/C No :
	Appd. 8/02/2016		P. Rating : PN20	
Drg./Part Designation.			Drg./Part No.	EC. No.
Dual Plate check valve (N.R.V) Assy.			0.00.09.11	00
ALL CHAMFER 0.5X45°			ALL DIMENSIONS ARE IN mm UNLESS OTHERWISE STATED.	
Sheet No. 1 of 1 Sheet				

Surface Finish Symbols					Machining Deviation for open Dimensions									REVISIONS					
Symbol	v	vv	vvv	vvvv	Dim.	Over	6	30	120	315	1000	2000	4000	ZONE	REV	DESCRIPTION	DATE	APPROVED	CHD. BY
Raw (Smooth un m/c'd)	Rough	smooth	Finish	Fine Finish	Up to & Inc.	6	30	120	315	1000	2000	4000							
Ro µm	25-12.5	6.3-1.6	0.8-0.2	0.1-0.025	Tolerance	±0.1	±0.2	±0.3	±0.5	±0.6	±1.2	±2	±3						