

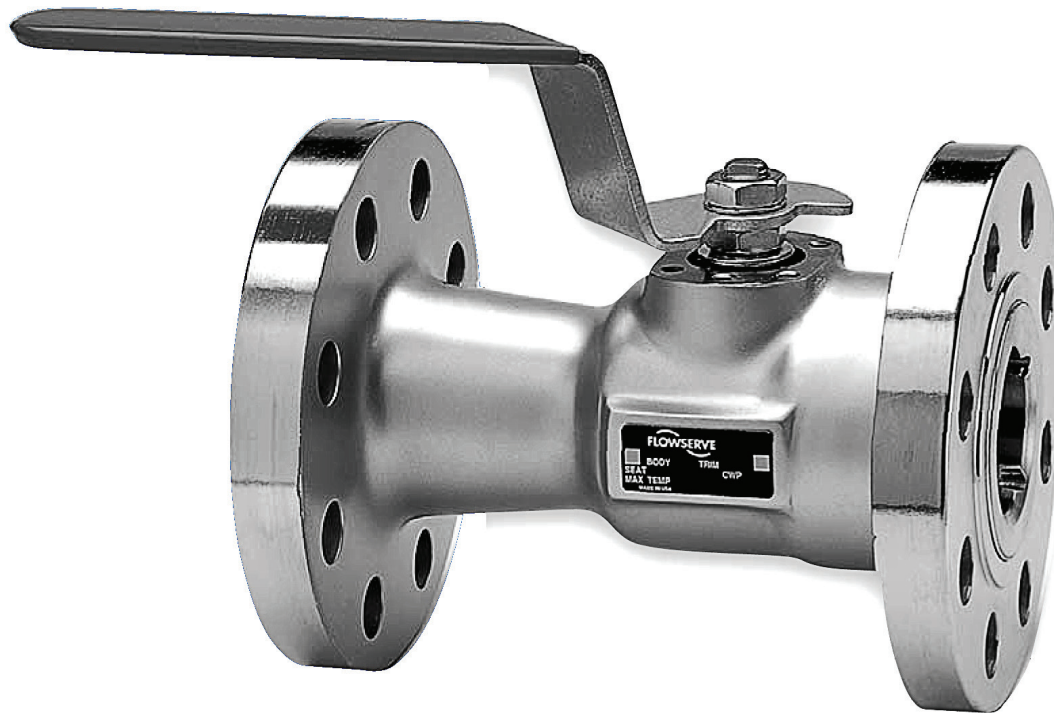

## *TECHNICAL BULLETIN*

# *Audco Ball Valve*

*Reduced Bore Fire safe Flanged Ball Valves 51/52 Series*



*Experience In Motion*

*With the Series 51/52 designed to BS EN ISO 17292 / API 6D, AUDCO brings to the market a reduced bore valve which combines low cost of ownership and long service life with high operational safety and a range of features which sets the standards for others to follow.*

What remains unchanged however is Audco's total dedication to quality and service support. All of this is the result of following one simple strategy - to listen and respond to the needs of our customers.

## 51/52 Valve Assembly

**Anti-blowout stem** - Inserted from inside of valve body for greater safety

**Actuator mounting** - Conforms to ISO 5211 for ease of actuation

**Gland nut** - Does not need to be removed for actuator mounting thereby maintaining valve integrity

**Anti-static stem** - Ensures electrical continuity between ball and body

**Body seals** - Flexible Graphite as standard for fire safe integrity maintained with metal to metal secondary seal

**Ball** - 316 stainless steel as standard with pressure equalising hole to balance cavity pressure with line pressure when valve is open. Parallel ported ball maximises flow and minimises pressure drop

**Insert** - Screwed insert designed to withstand full line differential pressure

**Seats** - Wide range of seat materials to suit customer applications.

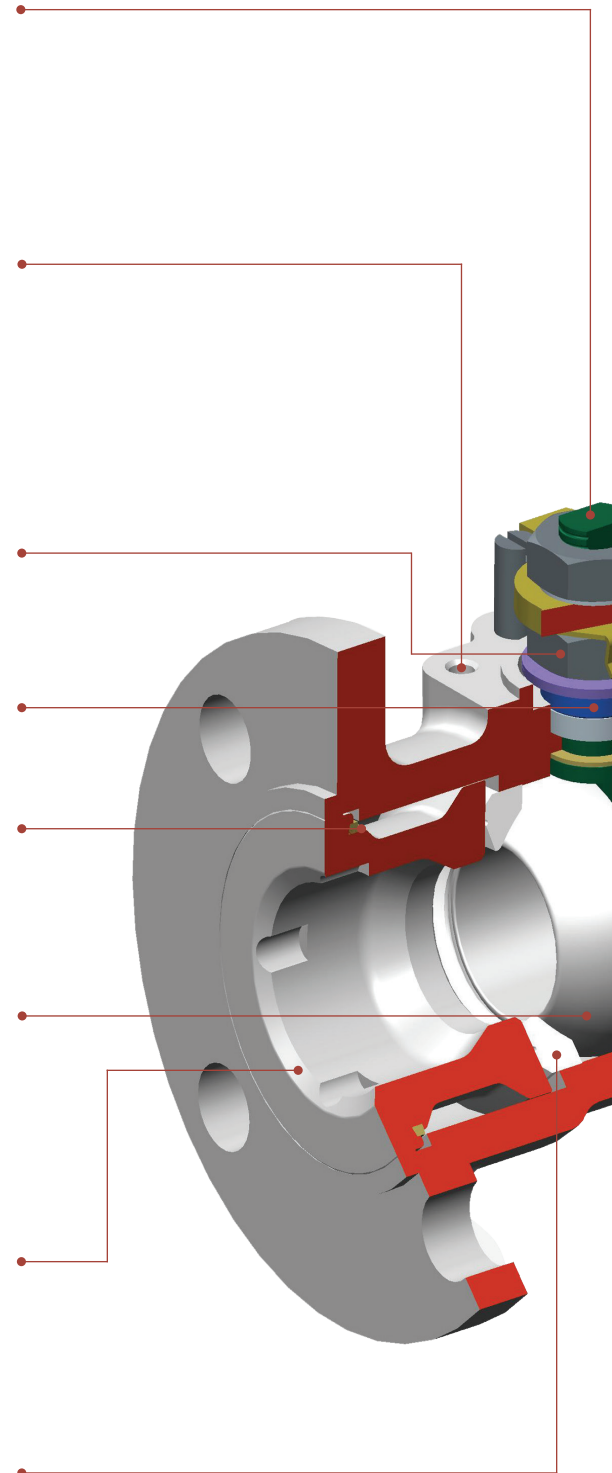

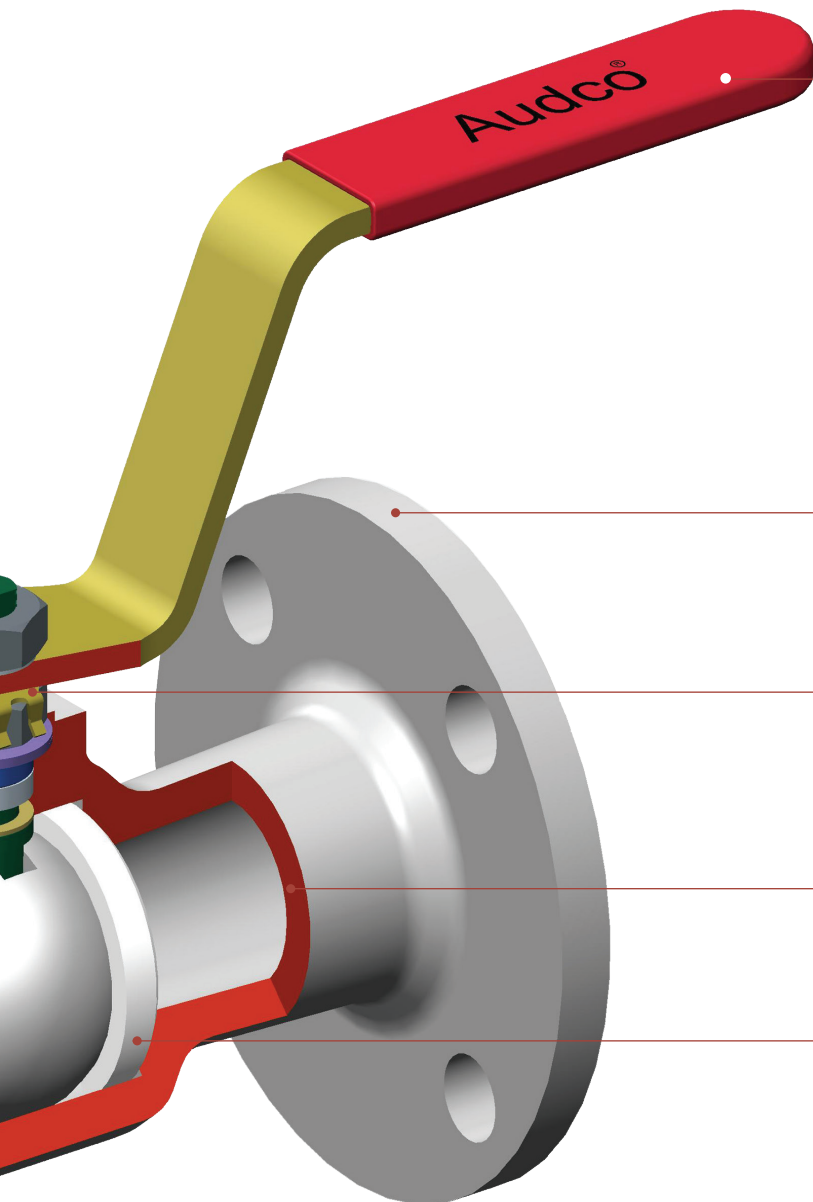

• **Wrench** - Ergonomically designed for ease of operation

• **Flange Connectors** - Integral to body complying with all major international standards or alternatively to meet specific customer needs

• **Locking clip** - Maintains position of gland nut during actuation for long leak-free performance

• **Materials of Construction** - Bodies are manufactured from cast material

• **Seat Design** - Cavity pressure relieving (CPR) seats ensure that pressure generated through media expansion when the valve is closed is safely relieved upstream

**Reduced Bore Fire safe Flanged Ball valve parts**

DN15 - DN50

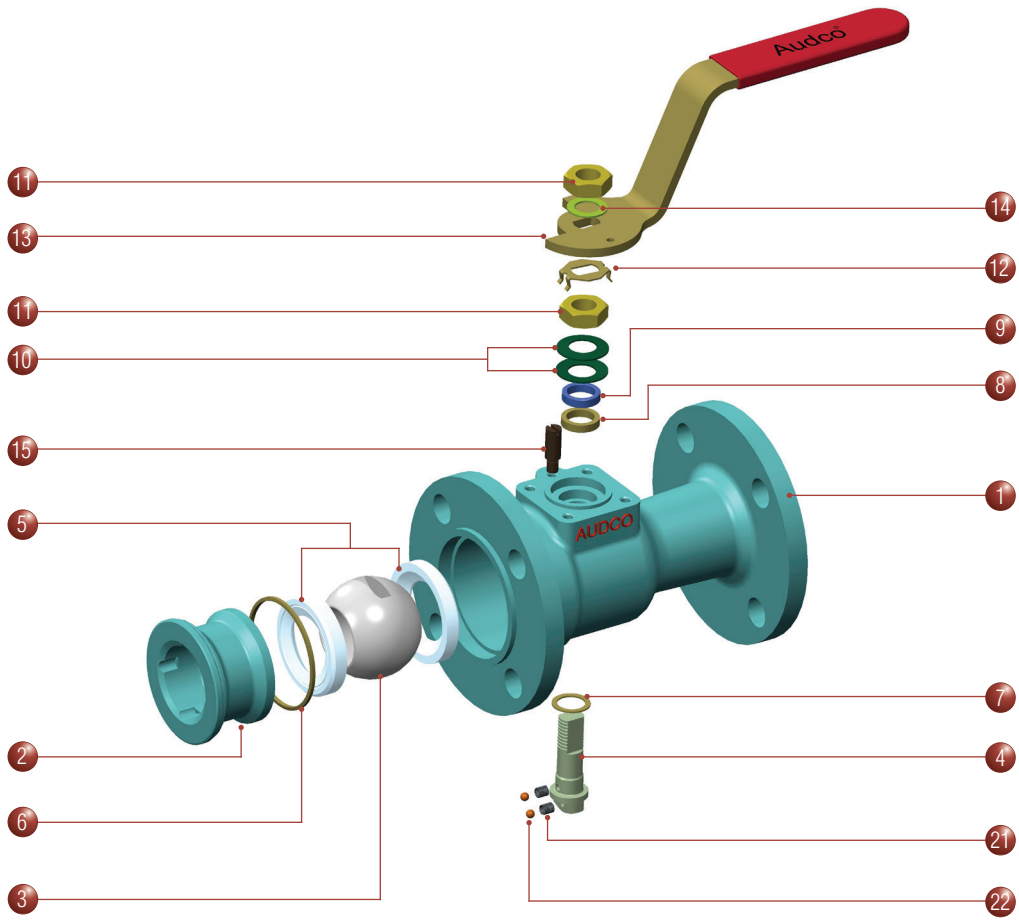

DN80 - DN200

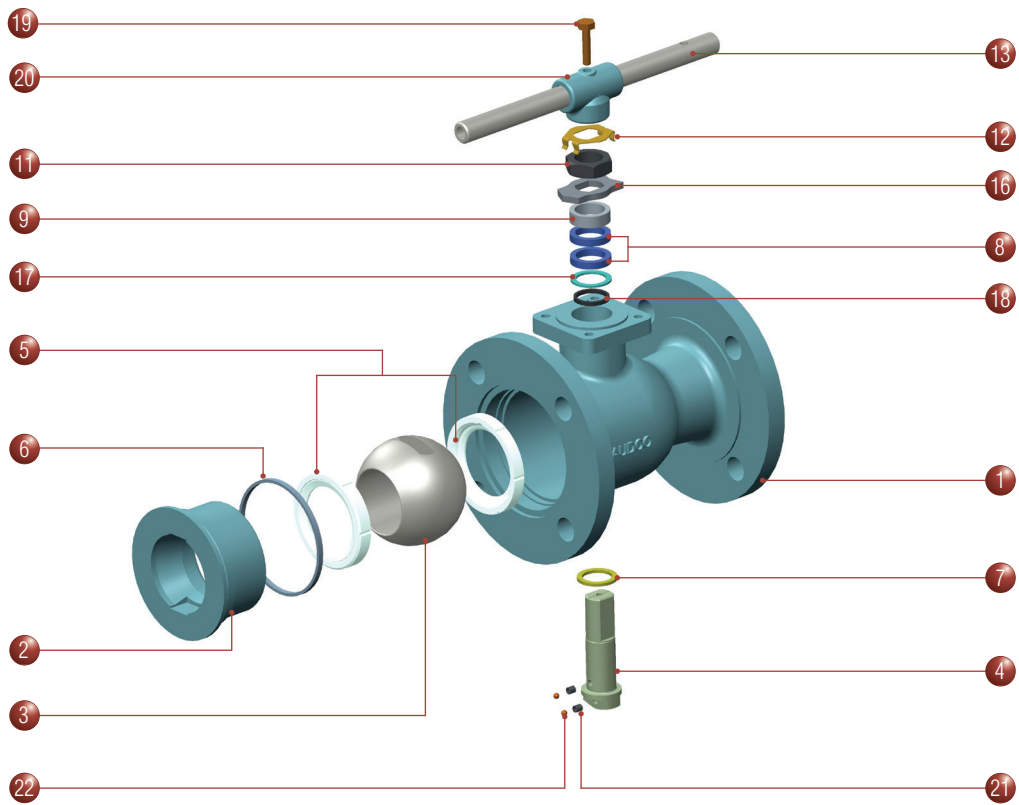

## Parts and Material Specification

Item	Description	Material	Item	Description	Material
1	Body	Stainless Steel ASTM-A351 CF8M Carbon Steel ASTM A216 WCB	12*	Gland Nut Locking Clip	Carbon Steel Rustproofed
2	Insert	Stainless Steel ASTM-A351 CF8M Carbon Steel ASTM A216 WCB	13	Wrench	Stainless Steel/ Carbon Steel
3	Ball	Stainless Steel ASTM-A351 CF8M ASTM A479 316	14	Spring washer	Stainless Steel
4	Stem	Stainless Steel 316	15	Stop Pin	Stainless Steel/ Carbon Steel
5*	Seat Ring	PTFE Virgin, PTFE 25% glass filled, Fluorfill, PEEK, metal or other ptions	16	Stop Indicator	Stainless Steel 316/ Zinc Plated Carbon Steel
6*	Body Seal	Flexible Graphite/ Virgin PTFE	17	Stem Location Ring	Stainless Steel 316
7*	Stem Thrust Seal	PTFE 25% glass filled	18	Secondary Stem Seal	Virgin PTFE
8*	Gland Packing	Flexible Graphite	19	Wrench Fixing Bolt	Carbon Steel
9	Gland	Stainless Steel 316	20	Wrench Head	S.G Iron/ Zinc Plated Carbon Steel/ Carbon Steel
10*	Disc Spring	Stainless Steel	21	Anti-Static Spring	Stainless Steel
11	Gland/ Wrench Nut	Zinc Plated Carbon Steel/ Stainless Steel	22	Anti-Static Plunger	Stainless Steel

\*Items marked thus denote component supplied in repair kit.

## Pressure/Temperature Rating

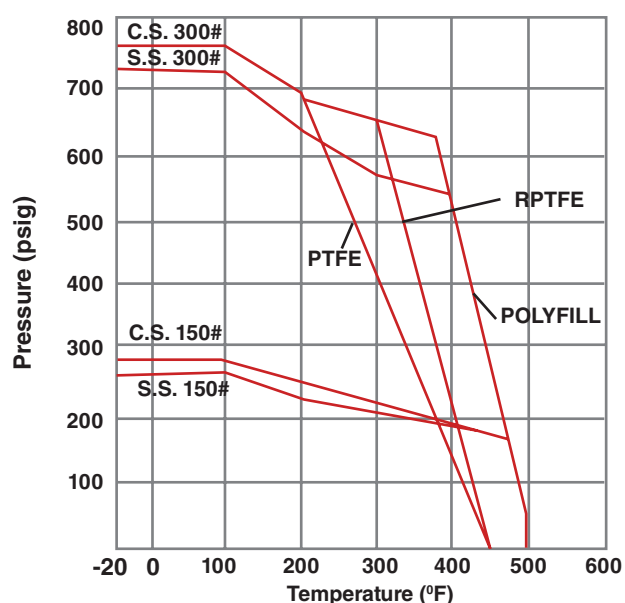

**NOTE:** Max. working pressure/temperature limited by both flange rating, seat and body seal capability.

## Technical Information

Valve size	Series	Weight kg	Flow Coefficients Cv
DN15	51	2	8
	52	2.5	
DN20	51	3	12
	52	3.4	
DN25	51	3.6	32
	52	4.3	
DN40	51	5.9	82
	52	7.3	
DN50	51	8.2	120
	52	10	
DN80	51	17.9	350
	52	22.7	
DN100	51	28.1	670
	52	36.3	
DN150	51	48	874
	52	70	
DN200	51	120	1583
	52	170	

## General Assembly

51 Series - Reduced bore class 150

52 Series - Reduced bore class 300

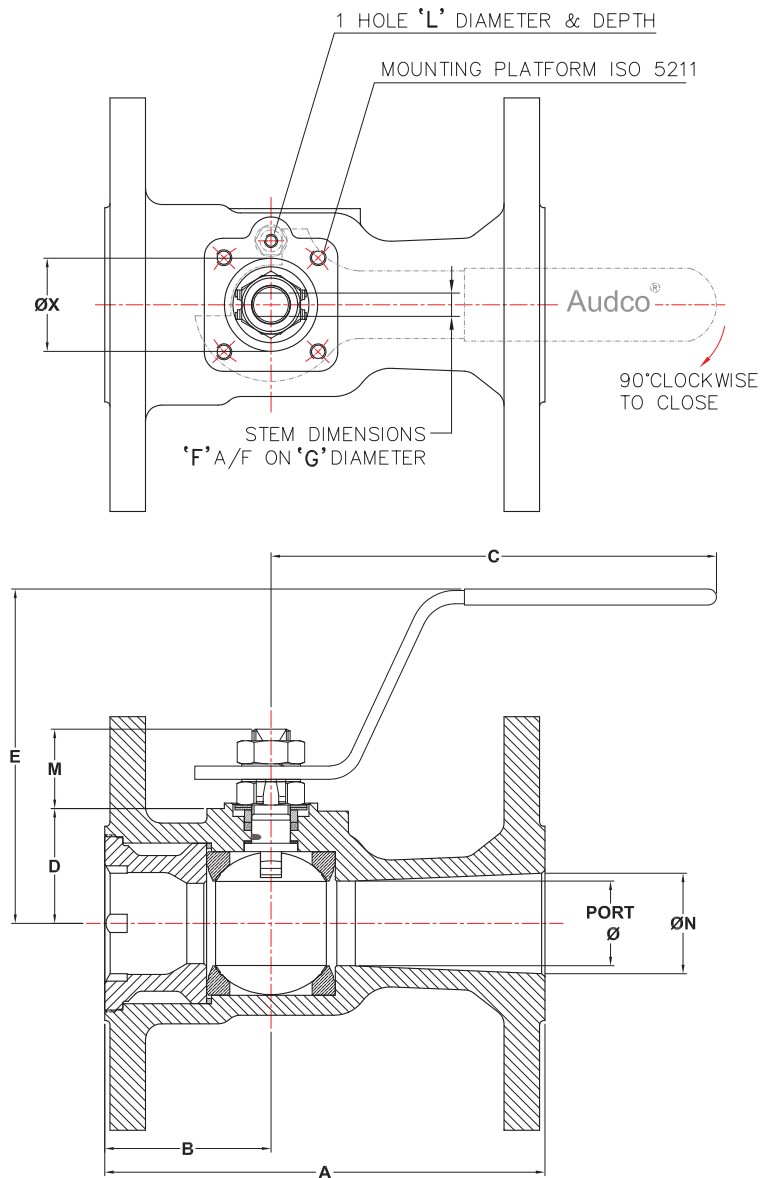

## Valve Dimensions (mm)

51/52 Series (DN15 - DN50)															
Valve Size	Port	A		B		C	D	E	STEM		M	N	L THREAD & DEPTH	X	ISO MTG
		51	52	51	52				F - A/F	G - THREAD					
15	11.0	108	140	46		155	21.95 21.65	98	5.5	3/8"-24 UNF	18	13.5	M5x0.8p 6.0 MIN	25	F03
20	14.3	117	152	49.6		155	24.27 24.01	98	5.5	3/8"-24UNF	18	17.5	M5x0.8p 6.0 MIN.	30	F04
25	20.6	127	165	57.1		168	31.21 30.95	111	7.5	7/16"-20UNF	25	24.5	M8x1.25p 10.0MIN.	30	F04
40	31.8	165	190	62.3	82.7	168	43.31 43.05	126.4	8.6	9/16"-18UNF	30	37.7	M6x1.0p 6.0 MIN.	35	F05
50	38.1	178	216	67.8		193	48.76 48.50	131.5	8.6	9/16"-18UNF	30	48.1	M8x1.25p 10.0 MIN.	35	F05

## General Assembly (DN80-DN200)

51 Series - Reduced bore class 150

52 Series - Reduced bore class 300

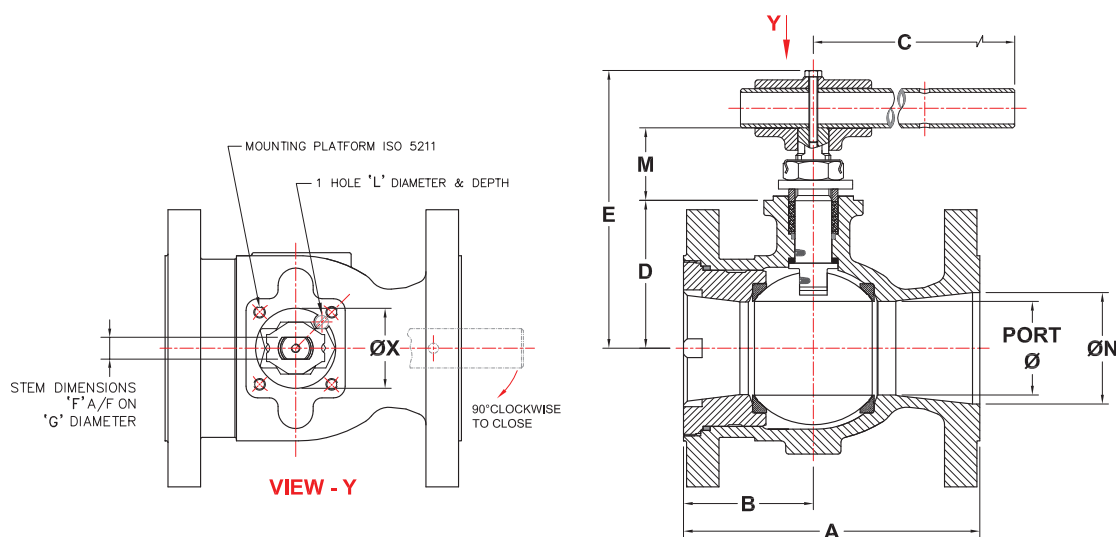

### Valve Dimensions (mm)

51 – Series (DN80 – DN200)													
Valve Size	Port	A	B	C	D	E	STEM		M	N	L THREAD & DEPTH	X	ISO MTG
							F - A/F	ØG					
80	64.0	203	89	350	101.7 101.3	190	15.1	21.1	51.1 48.4	76.8	M6x1.0p 6.0 MIN	55	F07
100	76.2	229	82	350	112.4 111.6	201	15.1	21.1	51.1 48.4	102.1	M6x1.0p 6.0 MIN	55	F07
150	102.3	267	129	557	140.6 139.8	235	19.3	27.1	55.9 53.2	151.5	M8x1.25p 10.0 MIN	70	F10
200	151.0	292	144.5	850	182.4 181.6	310	26.6	33.1	73.0 70.3	203.3	M10x1.5p 12.0 MIN	85	F12

52 – Series (DN80 – DN200)													
Valve Size	Port	A	B	C	D	E	STEM		M	N	L THREAD & DEPTH	X	ISO MTG
							F - A/F	ØG					
80	64.0	282	89	350	101.7 101.3	190	15.1	21.1	51.1 48.4	76.8	M6x1.0p 6.0 MIN	55	F07
100	76.2	305	107	557	119.9 119.1	214	19.3	27.1	55.7 53.0	102.1	M8x1.25p 10.0 MIN	70	F10
150	102.3	403	129	850	147.1 146.3	275	26.6	33.1	73.0 70.3	151.5	M10x1.5p 12.0 MIN	85	F12
200	151.0	419	144.5	850	194.6 193.8	327	30.4	37.8	77.4 74.7	203.3	M10x1.5p 12.0 MIN	100	F14

#### Notes

- When wrench not fitted, flats on stem when parallel to pipeline axis denote open position.
- Installation, Operating and Maintenance instructions are supplied with product and also available on request

#### Standards of Compliance

Valve Specification	BS EN ISO 17292, API 6D
Flanges 51	ASME B16.5 Class 150
Flanges 52	ASME B16.5 Class 300
Face to Face Lengths	ASME B16. 10
Pressure Test Specification	BS EN 12266 Part 1
Fire safe Specification	API 607
Sour Gas Applications	NACE MR0175/ISO 15156



## How to Order

Valve Size	Operator	Bore	Product series	Body / Insert	Ball & Stem	Seats	Body Seal	Ends
05 - DN15	L - Lever / Wrench	R - Reduced bore	51	4 - Carbon steel	4 - Carbon steel	T - PTFE	T - PTFE	F1 - ASME B16.5 CL.150
07 - DN20	G - Gear		52	6 - 316 S.S	6 - 316 S.S	R - RPTFE	G - Graphite	F2 - ASME B16.5 CL.300
10 - DN25	B - Bare stem for actuation					P - Polyfill		
12 - DN32	A - Actuator							
15 - DN40								
20 - DN50								
25 - DN65								
30 - DN80								
40 - DN100								
60 - DN150								
80 - DN200								

For any other additional requirement please specify.

**Ordering Example:** A valve size DN80 Series 51 with Cast steel body and Insert, 316 ball and stem, PTFE seats and seals with flanged ends class 150 Lever operated. The catalogue numbering shall be "30LR-5146TT-F1"

### Flowserve India Controls Pvt Ltd,

B-8, CMDA Industrial Area,  
Maraimalai Nagar - 603 209,  
Kanchipuram Dist, Tamil Nadu, India.  
(T) +91-44-27452323  
(F) +91-44-27452327  
Email : audcoplugindia@flowserve.com  
audcoslimsealindia@flowserve.com

FCD MMNCAT0004-00 04/14.

#### To find your local Flowserve representative

or for more information about Flowserve Corporation,  
visit [www.flowserve.com](http://www.flowserve.com)

Flowserve Corporation has established industry leadership in the design and manufacture of its products. When properly selected, this Flowserve product is designed to perform its intended function safely during its useful life. However, the purchaser or user of Flowserve products should be aware that Flowserve products might be used in numerous applications under a wide variety of industrial service conditions. Although Flowserve can (and often does) provide general guidelines, it cannot provide specific data and warnings for all possible applications. The purchaser/user must therefore assume the ultimate responsibility for the proper sizing and selection, installation, operation, and maintenance of Flowserve products. The purchaser/user should read and understand the Installation Operation Maintenance (IOM) instructions included with the product, and train its employees and contractors in the safe use of Flowserve products in connection with the specific application.

While the information and specifications contained in this literature are believed to be accurate, they are supplied for informative purposes only and should not be considered certified or as a guarantee of satisfactory results by reliance thereon. Nothing contained herein is to be construed as a warranty or guarantee, express or implied, regarding any matter with respect to this product. Because Flowserve is continually improving and upgrading its product design, the specifications, dimensions and information contained herein are subject to change without notice. Should any question arise concerning these provisions, the purchaser/user should contact Flowserve Corporation at any one of its worldwide operations or offices.

© 2013 Flowserve Corporation, Irving, Texas, USA. Flowserve is a registered trademark of Flowserve Corporation.